



## PROGRAMMED MICRO- AND NANOSCAL MODULES

Oleksandr Melnyk\*, Viktoriia Kozarevych

State University "Kyiv Aviation Institute", Kyiv, Ukraine

### ARTICLE INFO

#### Article history:

Received 4 March 2026

Revised 26 April 2026

Accepted 18 May 2026

#### Keywords:

micro- and nanomodules,  
programmable logic devices,  
majority logic, computer-aided  
design, multiplexers

<http://doi.org/10.62853/GALJ9367>

### ABSTRACT

*The article is devoted to the analysis of topical antagonistic issues regarding the implementation of new computer programming methods that can be used to reproduce heterogeneous binary functions of several arguments based on micro- and nanoelectronic multiplexer modules. The growth of specialization of modern large integrated circuits comes into conflict with their universality, which increases the cost of design work and reduces the production volumes of typonominal devices. The trade-off between specialization and versatility should be minimized by computer-aided design of micro- and nano-sized modules with programmable logic. Programming is not performed to create algorithms for processing discrete information, as implemented by a microprocessor, but by logical settings of multiplexer micro- and nanodevices. The results of the combined simulations obtained in the work confirm the equivalence of their functioning, as well as the advantages of cell-based Coulomb nanomultiplexers in reliability, technological scalability, energy efficiency, speed, and disadvantages in exclusively cryogenic ultra-low temperature applications. Obviously, the evolution of microelectronics will continue only in the context of the widespread introduction of nanoscale modules with new functional principles of operation.*

© 2026 Journal of the Technical University of Gabrovo. All rights reserved.

## 1. INTRODUCTION

Programming of micro- and nanoelectronic multiplexer devices does not involve creating algorithms for processing input multi-argument functions by changing the working programs, as is usually implemented by microprocessors. It concerns technological changes in the internal structure of nanoelectronic circuits in such a way as to ensure the implementation of the necessary functions at the structural-logical level.

As nanoelectronics continues its development based on complementary metal-oxide-semiconductor transistors (CMOSTs), it is currently necessary to overcome significant technological and quantum limitations inherent in modern microelectronics. Quantum cellular automata (QCA) are considered a promising replacement for the existing CMOS technology due to their ability to overcome physical scaling limitations. The main difference is that the principle of operation of CMOSTs is based on the drift of electric charges of both types. Obviously, it is p-channel CMOSTs that limit the speed of microelectronic modules. An additional limitation on the formation of logical levels is also constrained by the recharge time of the CMOS capacitance. QCAs use the polarization interaction of electron positions without current flow. The drift velocity of charges in CMOSTs is 6 orders of magnitude lower than inertialess tunneling in QCA cells. The frequency range of QCA extends to 100 THz, while that of CMOST does not exceed 1 GHz. Currently, QCA is the most economical component of nanoelectronics (<10-20 J). Their main

drawback is the need for a cryogenic temperature range (<5K). Therefore, QCA remain operable in space applications. Thus, a comparison of the operational characteristics of micro- (on CMOST) and nanomodules (on QCA) indicates the advantages of the latter, especially in energy efficiency and speed [1, 3].

## 2. PROBLEM STATEMENT AND PURPOSE OF THE WORK

In this article, the mathematical provisions of Boolean and majority logic will be used to form new equivalent circuits of micro- and nanomultiplexer module models. Their automated configuration and modeling will be performed for comparative analysis of the reproduction of discrete functions. The purpose of the research is to create identical models of micro- and nano-sized modules for the stage of automated circuit design for modern CAD complexes [2].

## 3. ANALYSIS OF RECENT RESEARCH

Experiments in the field of programmable micro- and nanomodules are actively developing, and a significant part of the attention of scientists is focused on the computer design of such systems. The first significant developments in this field occurred as a result of the creation of multi-structure systems built on the basis of universal, functionally complete modules. Such modules turned out to be one of the promising trends in the development of modern microelectronics [1]. These studies demonstrated

\* Corresponding author. E-mail: viktoriia.kozarevych@npp.kai.edu.ua

the possibility of automated design of micro- and nanocircuits capable of implementing 16 two-argument and 256 three-argument functions based on multiplexers [2]. However, there are significant difficulties in simplifying these circuits, which leads to excessive complexity in implementation and their universal application. An important aspect of the research was the improvement of micro- and nanocircuit programming methods for reproducing various functions of Boolean algebra and majority logic [3, 4]. The scientists proposed effective algorithms for automated programming of microcircuits with a high level of integration, which became the basis for the further development of nanodevices with programmable logic [7]. Despite significant progress in this area, the task of effective automated design still remains open, and today the problem of simplifying algorithms and their adequate reproduction is the subject of active discussions.

Special attention is paid to the issue of the influence of temperature conditions on the performance of nanocircuits, in particular, operation at cryogenic temperatures. Studies have shown that such conditions can significantly affect the operation of nanodevices, stimulating the search for new approaches to improve their quality and stability of operations [8, 9].

**4. PROGRAMMING UNIVERSAL LOGIC NANODEVICES**

To use universal logic nanomodels, signals of various arguments of the function being reproduced are fed to the select line, and the data lines act as programmable. For a digital device with two input arguments  $x_1, x_0$ , four discrete combinations are possible: 00, 01, 10, 11, and this allows us to synthesize 16 different output functions.

Fig. 1a shows the graphic designation multiplexer (or data selector) 2-to-1 with two data lines are labeled  $D_1$  and  $D_0$ , one select line (or address line) are labeled  $A$ , one output is available uncomplemented form, and is thus labeled  $f_{MUX}$ .

As can be seen from the truth table (Fig. 1b), the output  $f_{MUX}$  selects one of data line depending on the of  $A$ . For  $A=0$  select  $D_0$  and for  $A=1$  select  $D_1$ . So  $f_{MUX}=1$  for sets  $\overline{A}D_0D_1, \overline{A}D_0\overline{D_1}, \overline{A}D_1D_1, \overline{A}D_1\overline{D_1}$  and with the equivalent model of the microcircuit (Fig. 1c) full-blown express (completed disjunctive normal form CDNF) of the Boolean function  $f_B$  acquires the values of constituents "1" for four minterms  $\sum(100,110,011,111)$ , and consists of the sum-of-products (the logical disjunction four products):

$$f_B = \overline{A}x_1x_0 \vee \overline{A}x_1\overline{x_0} \vee Ax_1x_0 \vee Ax_1\overline{x_0} = 1 \tag{1}$$

Corresponding equation (1) Karnaugh map with sum of four products (minterms) consist two horizontal unitary subcubs:

|                |                     |                     |          |                     |
|----------------|---------------------|---------------------|----------|---------------------|
|                | $\overline{x_1x_0}$ | $\overline{x_1x_0}$ | $x_1x_0$ | $\overline{x_1x_0}$ |
| $\overline{A}$ | 0                   | 1                   | 1        | 0                   |
| $A$            | 0                   | 0                   | 1        | 1                   |

Obviously, we will get the following disjunctive normal forms (DNF) or minimal product-of-sums forms:

$$f_B = Ax_1 \vee \overline{A}x_0 \tag{2}$$

To implement Boolean functions of several arguments, it is necessary, first, to obtain their DNF, and, second, to create a micromodule programming algorithm for their synthesis. For example, using the de Morgan duality law [4] for the logical function of the inversion of the disjunction  $f_I = \overline{x_1 \vee x_0}$  we obtain the DNF  $f_I = x_1x_2$ , and implement the programming algorithm by comparing the DNF of the function  $f_I$  with the function (1).

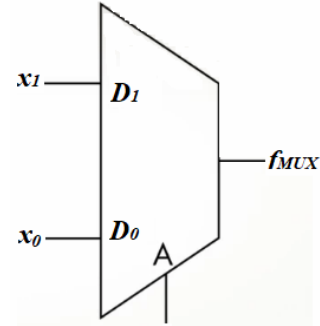

a

| $D_0$ | $D_1$ | $A$ | $f_{MUX}$       |
|-------|-------|-----|-----------------|
| 0     | 0     | 0   | $D_0 = x_0 = 0$ |
| 0     | 1     | 0   | $D_0 = x_0 = 0$ |
| 1     | 0     | 0   | $D_0 = x_0 = 1$ |
| 1     | 1     | 0   | $D_0 = x_0 = 1$ |
| 0     | 0     | 1   | $D_1 = x_1 = 0$ |
| 0     | 1     | 1   | $D_1 = x_1 = 1$ |
| 1     | 0     | 1   | $D_1 = x_1 = 0$ |
| 1     | 1     | 1   | $D_1 = x_1 = 1$ |

b

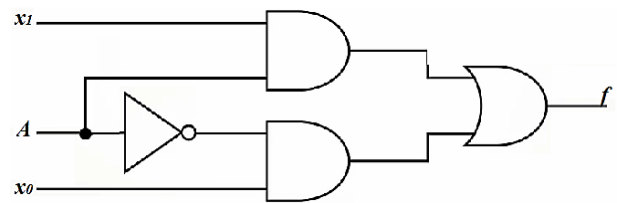

c

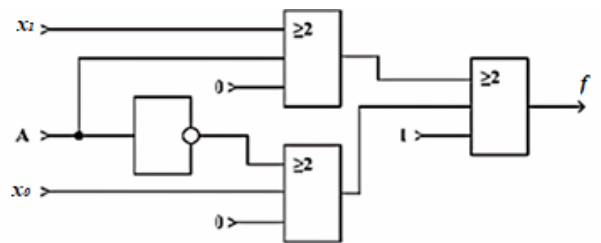

d

Fig. 1. One-select line multiplexer (a), its truth table (b) and equivalent micro- (c) and nanocircuits (d)

Thus, to program one select line  $A$ , variations of signals  $x_1$  and  $x_0$  should be applied to two data lines  $D_1$  and  $D_0$  of the itself micromodule. Table 1 illustrates the results of the formation of programming functions  $f_{pr}$  for it and, in

fact, the reproduction of the NOR function by the multiplexer itself  $f_{MUX} = f_I$ .

In a similar way, for the equivalent nanocircuit of multiplexer 2-of-1 (Fig. 1d), created on the basic three majority elements 2-of-3 (ME) and one inverter. Two MEs with inverter perform logic multiplication AND [13, 14], since on the third inputs has a negative polarization of -1 as show in Fig. 3a. The output ME emplemente logical addition OR of the signals from two input MEs due to the positive polarization +1. The majority function  $f_M$  of such a model for a nanomultiplexer has next form:

$$f_M = maj_{out}(1)[maj(-1),maj(-1),I]= maj[(Ax_1 \vee A.0 \vee x_1.0),(\overline{Ax_0} \vee A.0 \vee x_0.0),I] = Ax_1 \vee \overline{Ax_0} \quad (3)$$

where the marking *maj* is a majority operation of selecting the majority of binary values from an odd number (in this case three) of input arguments [5, 8].

The majority choice function (2 out of 3) in canonical or decimal forms has the form  $f_M = \sum(011, 101, 110, 111) = \sum(3, 5, 6, 7)$ . Table 2 lists four options for programming a nanoelectronic single-bit assembled from three MEs and one inverter (Fig. 1d).

**5. DISCUSSION OF THE RESULTS OF PROGRAMMING MICRO- AND NANOMODULES**

According to Fig. 1c, a two-data lines multiplexer was built on the Multi-Cap II CAD workspace [3, 4]. Fig. 2 shows the microcircuits of the computer implementation of the logical NOR function on four multiplexers (a), which are programmed according to the transformation (1) and Table 1, as well as the results of identical simulations of four corresponding waveforms (b).

Coulomb quantum cellular automata (QCA) are an example of majority modeling, according to which binary information is encoded by two diagonally arranged electrons in a QCA cell [7, 8, 12]. Single-electron

nanodevices based on quantum technology consist of nanoscale dielectric cells that have four semiconductor quantum Coulomb islands in the corners, and two free electrons that tunnel between them inertially. The previously created nanoelectronic circuit of the (Fig. 1d) is now reproduced on the QCA (Fig. 3a) as an initial task for simulation on the QCADesigner CAD [5, 6]. It consists of an inverter of the select line A at the inputs of the majority modules with programmable logic in the form of a negative polarization of -1.00 to perform the logical multiplication operation in equation (3). Nanocircuit in Fig. 3a consist of 17 QCAs, with a size of  $(18 \times 18)nm^2$ , with a distance between the centers of  $20nm$ . The diameter of the quantum islands is  $5nm$ . The total size is  $(138 \times 121)nm^2 = 0.02 \mu m^2$ . The output ME is programmed with a positive polarization of 1.00 to perform logical addition in the function  $f_M$  (3). Fig. 3b shows the results of modeling the waveforms of the nanoelectronic module, which exactly match the truth table (Fig. 1b), which confirms the adequacy of the programming.

QCA technology employs a clocking technique that controls circuit timine, unidirectional flow of polarizations and power supply  $3,8 \cdot 10^{-23} \div 9,8 \cdot 10^{-22} J$ . In QCA are four clocking zones with four operations: the switch, hold, release and relax phases [1, 10]. The phase of a clock zone is 90 degrees.

The comparison waveforms (Fig. 3b) shows that the nanocircuit implements incorrect function 011100 at 3K instant of 010100 at 0K. At 20K it loses its operability and reproduces the source “1” with equation for sum-of eight products from the Karnaugh map:

$$F_M(20K) = \overline{Ax_1x_0} \vee \overline{Ax_1x_0} \vee Ax_1x_0 \vee Ax_1x_0 \vee \overline{Ax_1x_0} \vee \overline{Ax_1x_0} \vee \overline{Ax_1x_0} \vee \overline{Ax_1x_0} = \overline{x_1} \vee x = I$$

**Table 1** Programming a microelectronic multiplexer module

| A                | $D_1$                             | $D_0$                             | $f_{pr}$                           | $f_{MUX}$   |
|------------------|-----------------------------------|-----------------------------------|------------------------------------|---|
| $x_1$            | $\overline{x_1} a\overline{b}o 0$ | $\overline{x_0}$                  | $D_1x_1(0) \vee D_0\overline{x_1}$ | $\overline{x_1x_0} = f_I = \overline{x_1} \vee x_0$ |
| $x_0$            | $\overline{x_0} a\overline{b}o 0$ | $\overline{x_1}$                  | $D_1x_0(0) \vee D_0\overline{x_0}$ |   |
| $\overline{x_1}$ | $\overline{x_0}$                  | $\overline{x_1} a\overline{b}o 0$ | $D_1\overline{x_1} \vee D_0x_1(0)$ |   |
| $\overline{x_0}$ | $\overline{x_1}$                  | $\overline{x_0} a\overline{b}o 0$ | $D_1\overline{x_0} \vee D_0x_0(0)$ |   |

**Table 2** Programming a nanoelectronic multiplexer module

| A                | $D_1$                         | $D_0$                                    | $f_{pr}$                           | $f_{MUX}$  |
|------------------|-------------------------------|--|------------------------------------|--|
| $x_1$            | $maj(x_1, \overline{x_1}, 0)$ | $maj(\overline{x_1}, \overline{x_0}, 0)$ | $D_1x_1(0) \vee D_0\overline{x_1}$ | Function (3),<br>$f_I = \overline{x_1} \vee x_0$ |
| $x_0$            | $maj(x_1, \overline{x_0}, 0)$ | $maj(\overline{x_1}, \overline{x_0}, 0)$ | $D_1x_0(0) \vee D_0\overline{x_0}$ |  |
| $\overline{x_1}$ | $maj(\overline{x_1}, x_0, 0)$ | $maj(\overline{x_1}, x_0, 0)$            | $D_1\overline{x_1} \vee D_0x_1(0)$ |  |
| $\overline{x_0}$ | $maj(\overline{x_1}, x_0, 0)$ | $maj(\overline{x_1}, x_0, 0)$            | $D_1\overline{x_0} \vee D_0x_0(0)$ |  |

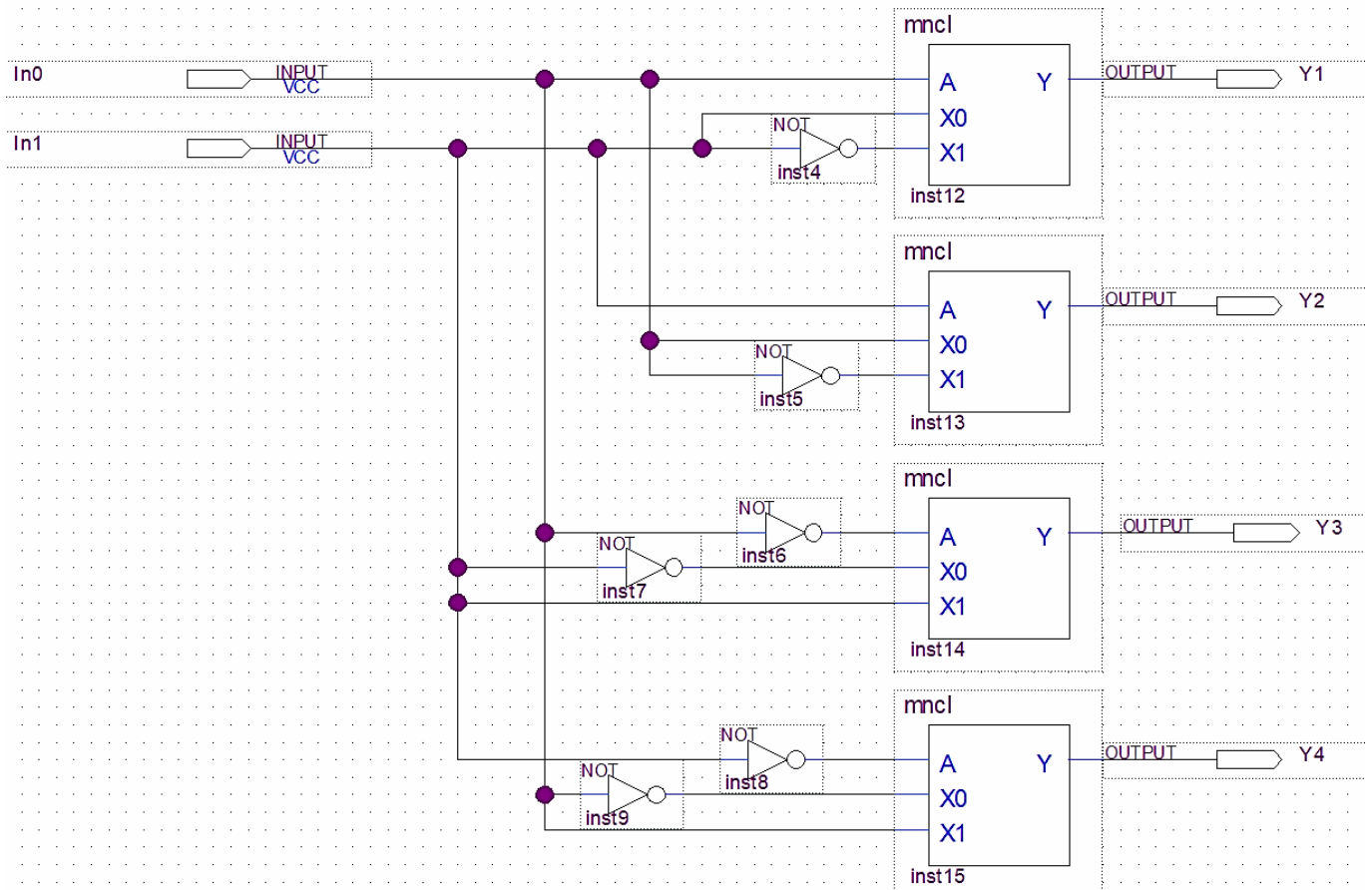

a

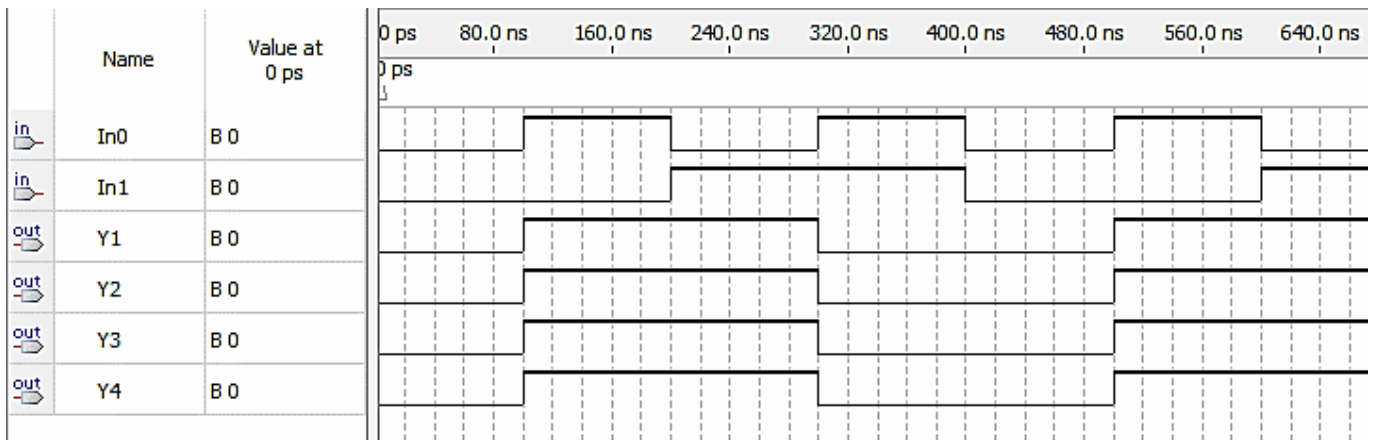

b

Fig. 2. Computer programming of the micromoduls (a) and results of simulation their waveforms (b)

For an example of using the nanomultiplexer model (Fig. 3a), a simulation of a configured logic block (CLB) was performed as part of the chip FPGA Actel company [10]. The CLB has two levels of multiplexing (Fig.4,a). The first low multiplexer has four data lines A, B and two select lines S. The final multiplexer is controlled by logic element (LE) "OR". Its logic function has the form:

$$F = (S_1 A_{11} \vee \overline{S_1} B_{11}) (S_3 \vee S_4) \vee (S_2 A_{21} \vee \overline{S_2} B_{21}) (\overline{S_3} \vee S_4) \quad (4)$$

where  $S_1, S_2$  and  $S_3, S_4$  are the select lines of the two multiplexers and two inputs of LE "OR";  $A$  and  $B$  are their data lines.

Total numbers QCA in nanocircuit was 79, QCA sizes are equal  $(18 \times 18) \text{ nm}^2$ , the distance between their centers is 20 nm. The diameter of the quantum islands is 5 nm. The total size is  $(338 \times 398) \text{ nm}^2 \approx 0,14 \mu\text{m}^2$ .

By comparing a logical function (4) of LCB and truth table (Fig.4b) the values of its parameters correspond indicators (Fig.4a, c) are found:

$$\begin{aligned} A_1 = S_1 = x_1, \quad A_2 = S_2 = 0, \quad A_4 = S_3 = x_0, \quad A_5 = S_4 = 0, \\ D_{11} = A_{11} = x_2, \quad D_{12} = B_{11} = 0, \\ D_{21} = A_{21} = 1, \quad D_{22} = B_{21} = 1. \end{aligned}$$

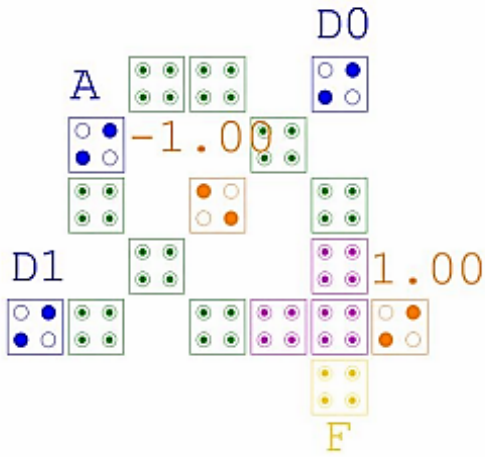

a

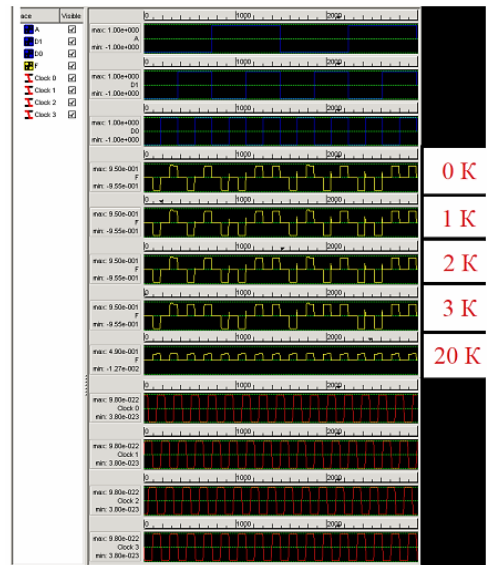

b

Fig. 3. Simulation for nanomodul NOR (a) and his waveforms (b)

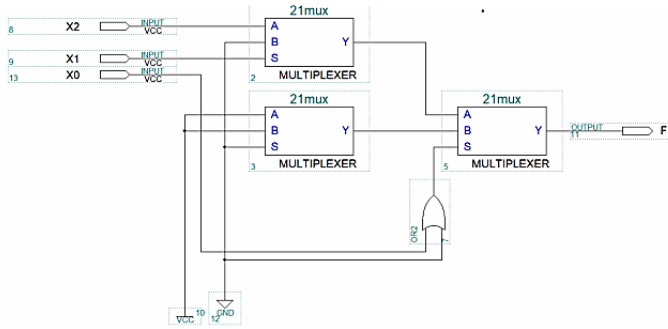

a

| $x_2$ | $x_0$ | $x_1$ | $F$ |
|-------|-------|-------|-----|
| 0     | 0     | 0     | 1   |
| 0     | 0     | 1     | 0   |
| 0     | 1     | 0     | 1   |
| 0     | 1     | 1     | 0   |
| 1     | 0     | 0     | 1   |
| 1     | 0     | 1     | 0   |
| 1     | 1     | 0     | 1   |
| 1     | 1     | 1     | 1   |

b

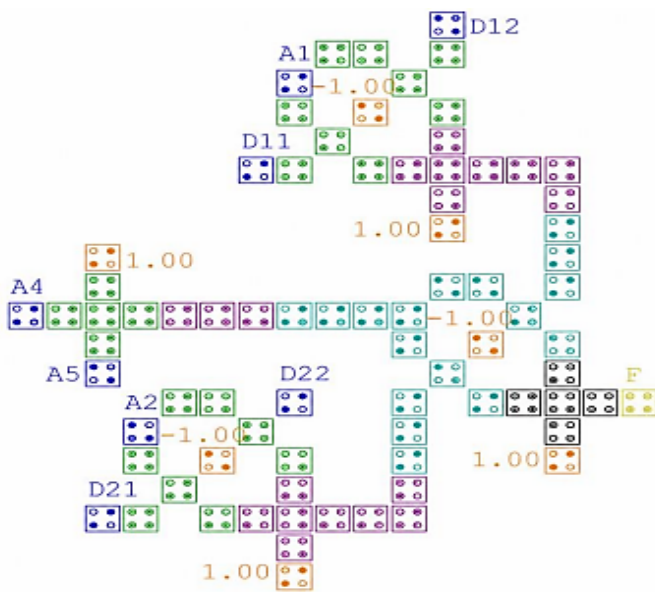

c

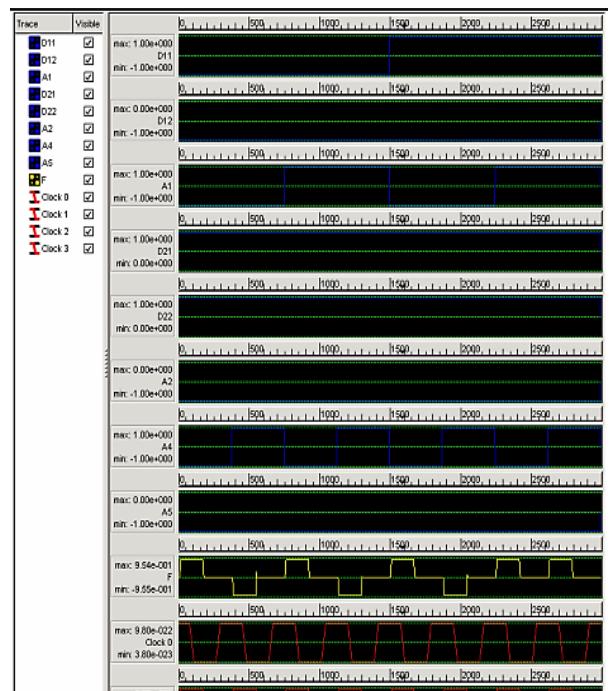

d

Fig. 4. Computer configuration of CLB Actel: equivalent circuit (a), truth table for  $F = x_2x_1 \vee x_0$  (b), equivalent QCA circuit for CAD QCA Designer (c), and the results simulation its waveforms (d)

In this case the equation (4) takes the next form:

$$F = (x_1 x_2 \vee 0 \overline{x_2}) (x_0 \vee 0) \vee (0.1 \vee 1.1) (\overline{x_0} \vee 0) = \\ = x_2 x_1 x_0 \vee \overline{x_0} = x_2 x_1 (x_0 \vee \overline{x_0}) \vee \overline{x_0} = x_2 x_1 \vee \overline{x_0},$$

which corresponds to the truth table and their waveforms (Fig. 4d).

Connecting to eight inputs of this CLB, it is possible to obtain up to 702 logical function from 2, 3 and even 8 variables:

$$F(8) = (x_1 \vee x_0) (x_7 x_5 \vee x_6 \overline{x_5}) \vee (\overline{x_1 \vee x_0}) (x_4 x_2 \vee x_3 \overline{x_2}) = \\ = x_7 x_5 x_0 \vee x_6 x_5 x_1 \vee x_6 x_5 x_0 \vee x_4 x_2 x_1 x_0 \vee x_3 x_2 x_1 x_0$$

## 6. RESEARCH PROSPECTS

The authors consider the development of new methods for programming nanomodules based on majority logic to be promising, since further miniaturization and increased performance are possible only with the introduction of single-electron nanodevices. In addition, research directions that contribute to the development of spintronics and biomolecular electronics nanomodules are promising [4, 11]. In addition, significant advantages in the future are provided by the development of new methods of automated modeling and design of nanomodules based on five-inputs MEs (3 on 5) [12] of three-dimensional MEs (qubits).

## 7. CONCLUSIONS

Since the development of microelectronics based on complementary metal-oxide-semiconductor transistors is limited by small-scale and quantum-technological effects [2, 3], the article gives priority to the use of nanomodules with programmable logic for the implementation of Boolean and majority functions. The developed algorithms (Tables 1 and 2) of automated programming of micro- and nanomodule (Fig. 2 and 3) confirmed the adequacy of the proposed models. However, a significant drawback of single-electronic nanomodules remains the exclusively cryogenic temperature range [8, 9], which currently determines their reliable operation only in space conditions.

The article proves that the created models of micro- (based on CMOS, Fig. 1c) and nano- (based on QCA, Fig. 1d) multiplexer modules for CAD information support accelerate the processes of automated reproduction of discrete functions (Fig. 2 and 3). This, in turn, expands the mathematical description of the stage of modeling nanomodules at the level of majority logic (equation (3)). Automated simulation confirmed the effectiveness of the functioning of the created mathematical models of micro- and nanomodules. The created algorithms allowed to

variably adjust programmable structures. A significant advantage of nano-sized modules is the minimum energy consumption from pulsed power supplies for synchronization circuits, since the energy Clocks does not exceed  $9,8 \cdot 10^{-22}$  J (Fig. 3b). However, the cryogenic range up to 5K remains critical for their stable operation (Fig. 3b), since the phenomenon of thermal generation of background charges creates the logic of operation of single-electron nanomodules, in which one bit of information is encoded by one electron.

## REFERENCES

- [1] Tougaw P., Lent S., Porod W., Bistable saturation in coupled quantum cellular automata, *Journal of Applied physics*, 74(5) (1993) 3558-3566, <https://doi.org/10.1063/1.108848>
- [2] Birla S., Dargan K., Singh N., *Low power design nanodevices and circuits for emerging application*, CRC Press (2022) 452 p. <https://doi.org/10.1201/9788/003459231>
- [3] Sicard E., Bendhia S., *Advanced CMOS Cell Design*, McGraw-Hill (2007) 385 p. ISBN:071509054,9780071509053
- [4] Hennessy J.L. Patterson D.A., *Computer Architecture: A Quantitative Approach*, Morgan Kaufmann, 2014, 856 p. ISBN:978-0-12-383872-8
- [5] Walus K., Dusart T., Budiman C., QCA Designer: A rapid design and simulation tool for QCA, *IEEE Transactions on Nanotechnology*, 3(4) (2004) 26-39, <https://doi.org/10.1109/TNANO.2003.820815>
- [6] QCADesigner, version 2.0.3. Available at [www.atips.ca](http://www.atips.ca)
- [7] Sen B., Gosman S., Towards modular design of reliable QCA logic circuits using multiplexers, *Computer Electronics Eng.*, 45(2) (2015) 42-54, <https://doi.org/10.1016/j.compeleceng.2015.05.001>
- [8] Melynk O.S., Kozarevych V.O., Arithmetic Logic Single-electron Nanocircuits, *Electronics and Control Systems*, 2(76) (2023) 68-77, <https://doi.org/10.18372/1990-5548.76.17670>
- [9] Cho H., Swartzlander E., Adder and multiplier design in quantum-dots cellular automata, *IEEE Trans on Computers*, 58(1) (2009) 721-729, <https://doi.org/10.1109/TC.2009.21>
- [10] Wolf W. *FPGA-Based Systems Design*, PRT Prentice Hall, (2004) 545 p. ISBN:0131424610, 9780131424616
- [11] Zohaib M., Navimipour N., Audemir M., A nano-scale design of arithmetic and logic unit for energy-efficient signal-processing devices based on a quantum-base technology, *Cluster computing*, (2025) <https://doi.org/10.007/5-10586-024-05073-3>
- [12] Melynk O.S., Kozarevych V.O., Kogut E.I., Two-digit Quantum-dot cells Multiplier, *Electronics and Control Systems*, 2(72) (2022) 52-57, <https://doi.org/10.18372/1990-5548.72.16943>